

## ICSZ Compensating Stacker

The stacker interlocks products crosswise to produce a solid bundle for optimal palletizing.

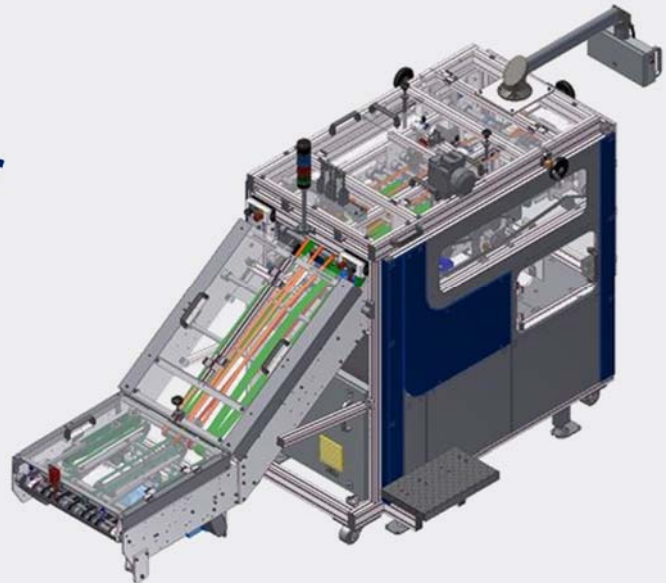

### Technical Specifications

#### Measurements

<b>Total height</b>	approx. 2228 mm
<b>Total width</b>	approx. 1377 mm
<b>Total length</b>	approx. 3478 mm (without swivel arm), depending on inlet height
<b>Input height</b>	600 - 900 mm
<b>Output height</b>	850 - 900 mm
<b>Height partial batch</b>	max. 160 mm
<b>Height complete bundle</b>	max. 300 mm
<b>Product width</b>	148 - 320 mm
<b>Product length</b>	190 - 480 mm
<b>Product diagonal</b>	max. 580 mm, attention please

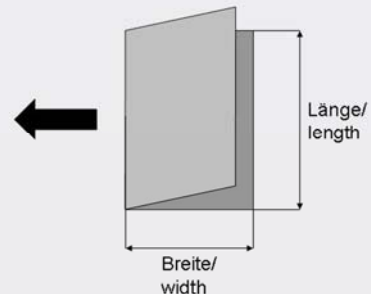

#### Pneumatic system

<b>Air pressure</b>	min. 6 bar
<b>Air consumption</b>	max. 1,0 Nm <sup>3</sup> /min., unooled, dry air

#### Electrical supply data

<b>Voltage</b>	400 V, 3 Phase, N, PE, 50 Hz
<b>Power input</b>	1,5 kW
<b>Fuse</b>	20 A slow-blow fuse
<b>Cycle time</b>	1.8 sec.

#### Example for production speed at DIN A4 (48 pages):

Shingle stream infeed between 30 and 60 mm

Guaranteed performance: 100.000 c/h. at 50 copies per partial bundle

Performance data refers to DIN A4 products without inserts.

# SEGBERT

PALLETIZING & AUTOMATION

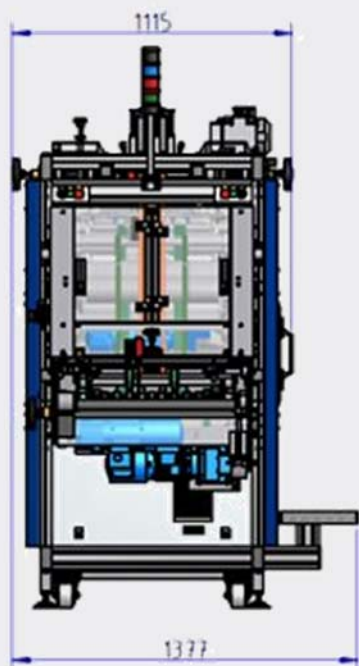
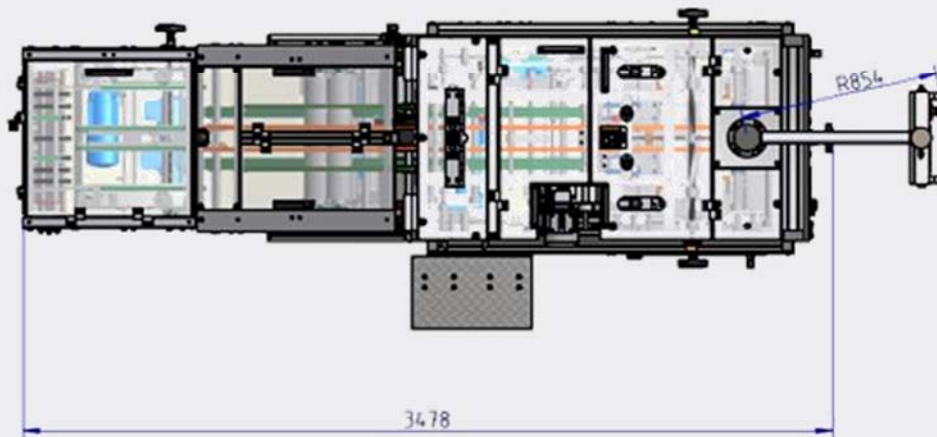
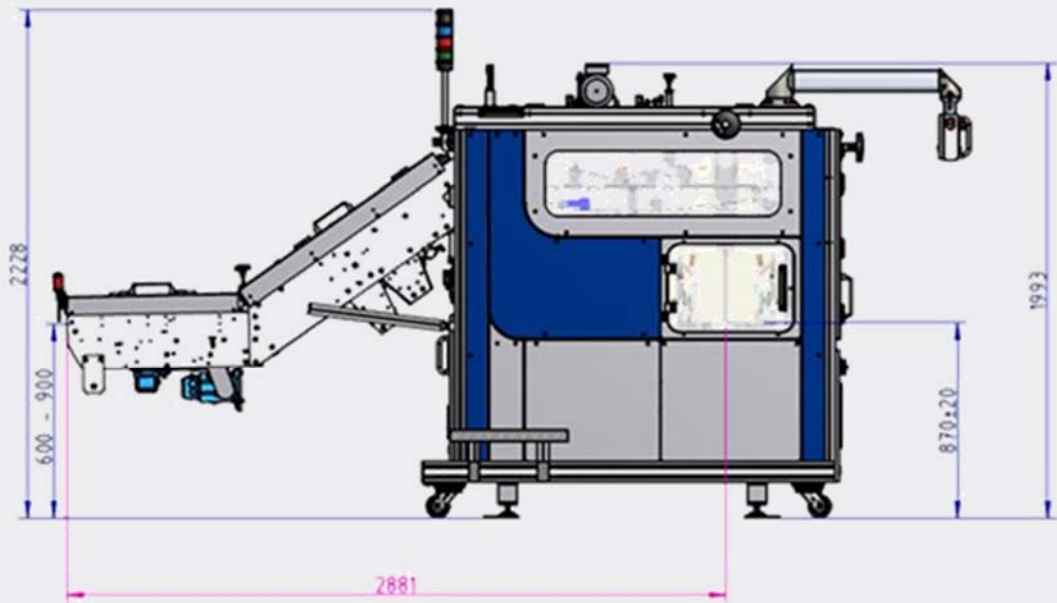

Gutenbergstraße 16  
D-48683 Ahaus

Telefon +49 (0) 25 61/95 04-0  
Telefax +49 (0) 25 61/95 04-20  
Mail [segbert@segbert.com](mailto:segbert@segbert.com)

Sitz der Gesellschaft: Ahaus  
Persönlich haftender Gesellschafter:  
Segbert GmbH

USt.-Id.Nr. DE 123788344  
Gerichtsstand:  
AG Coesfeld, HRB 4251

Geschäftsführer:  
Klaus Segbert

Volksbank Gronau-Ahaus eG  
IBAN: DE33 4016 4024 0602 0192 00  
BIC: GENODEM1GRN